



FABER-CASTELL
since 1761

Ecco Pigment



Finest Artists' Quality · Made in Germany

Sustainability at Faber-Castell

Change needs creativity

A sustainable future needs new ideas as well as people who are eager to shape that future in a creative way. We as Faber-Castell are a driving force for sustainable development in our industry: with our products, we motivate people to unleash their creative potential.

As a family-owned business in the ninth generation, we take our responsibility seriously. Sustainability is not a new trend for us, but an integral part of our value culture and a proven success factor in our company's history.

We understand sustainability in ecological, social and economic terms. We are pioneers in the industry with our own certified forest management for securing a long-term source of raw material. But we are also committed to biodiversity, renewable energies, the conservation of resources, equal opportunities and diversity. As a globally renowned brand company, we see ourselves as a key player in the economy: our actions have a significant impact on both the environment and society.



Wood from certified sustainable forestry is the most important raw material for the Faber-Castell product range.



The Faber-Castell Group works on reducing plastics or replacing them with recycled materials in packaging and products.



Faber-Castell offers a wide range of erasers. Erasers with this symbol are produced under strict quality control and are PVC-free.



Every product contains valuable raw materials. To extend their lifespans, many products are refillable.



Further information can be found on our sustainability website.
<https://www.faber-castell.com/corporate/sustainability>

Faber-Castell stands for quality

Faber-Castell is one of the world's leading manufacturers and marketers of quality products for writing, drawing and creative design – the brand name is world-famous. In the core area of woodcased pencils, the group is the most important and oldest manufacturer in the world with a production capacity of more than two billion pencils and coloured pencils.

Its Art & Graphic range allows Faber-Castell to enjoy a great reputation among artists and hobby painters. Prestigious creative minds have recognised this expertise since time immemorial – from Vincent van Gogh to Karl Lagerfeld. High quality artists' pigments ensure light resistance and thus brilliance and colour intensity for decades. All products are based on the same colour system, enabling reliable mixing techniques of artists' pencils, whether water-soluble or indelible.



Ecco Pigment



The Ecco Pigment is a fineliner with enormous potential. Equipped with a highly pigmented, lightfast ink, it is suitable for technical drawings, illustrating, calligraphy and for inscriptions on certificates and documents. On absorbent surfaces, the Ecco Pigment does not bleed through the paper and can be corrected on transparent paper with an ink eraser.

The ergonomic shape of the pen enables tireless drawing. The barrel and the cap of the Ecco Pigment are made from recycled plastic.

Ecco Pigment fineliners are available with line widths from 0.05 to 0.8 mm.





FABER-CASTELL
since 1761

9 line widths

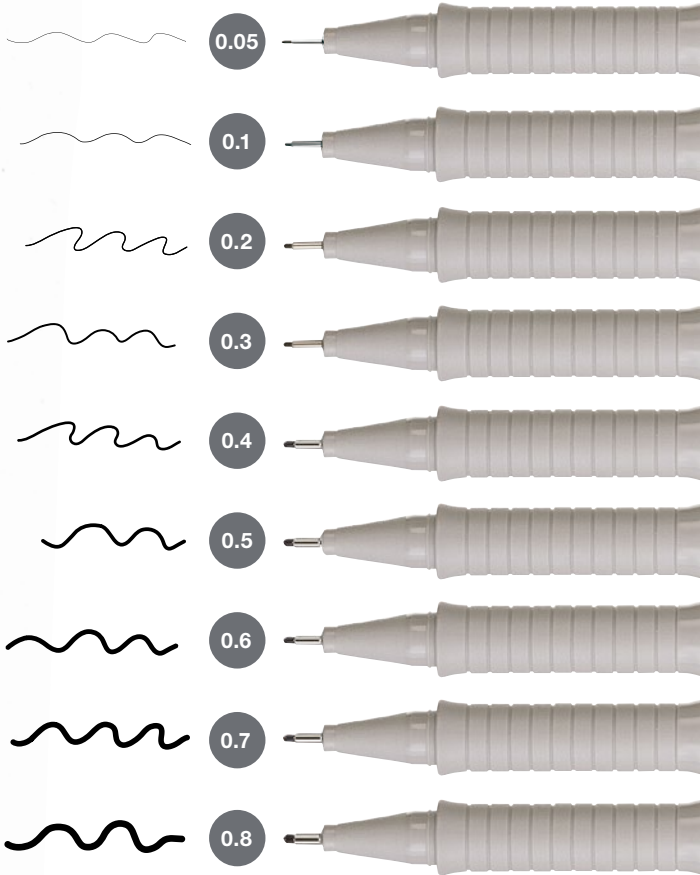

Techniques

Hatching

Parallel hatchings

Hatches drawn with parallel, densely spaced lines can melt into a single colour from a distance. The closer together the lines are, the darker the area appears.



Cross hatchings

New hues in a wide range of shades are created by overlapping lines in different directions or different colours. For cross hatching, lines are overlapped at different angles. Multi-coloured cross hatching can be used to create interesting colour mixes.

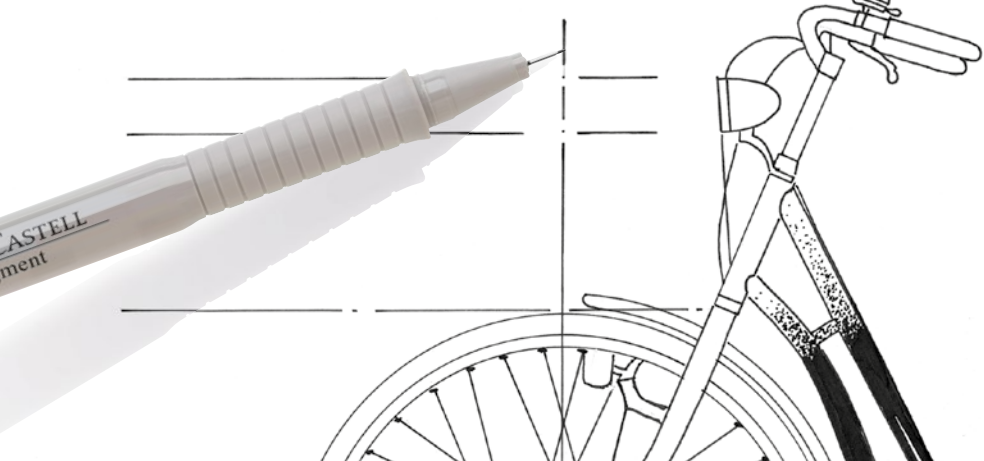

Pointillism

The word pointillism comes from the French word "point" = "dot". This painting technique uses the dot as the only stylistic element. Dots in various sizes and colours give the picture its shape, the density of the dots determines the tonal values of the finished picture. A key strength of the Ecco Pigment: The shape of the pen nib does not change even after several thousand dots, meaning that lines and dots retain their size and quality reliably.

The effect of pointillism is revealed when viewed from a distance: The further away the observer is from the picture, the more the dots merge into complete visual areas. An effect we are familiar with from the field of printing. Here too, a picture is created based on the density and overlapping of dots.

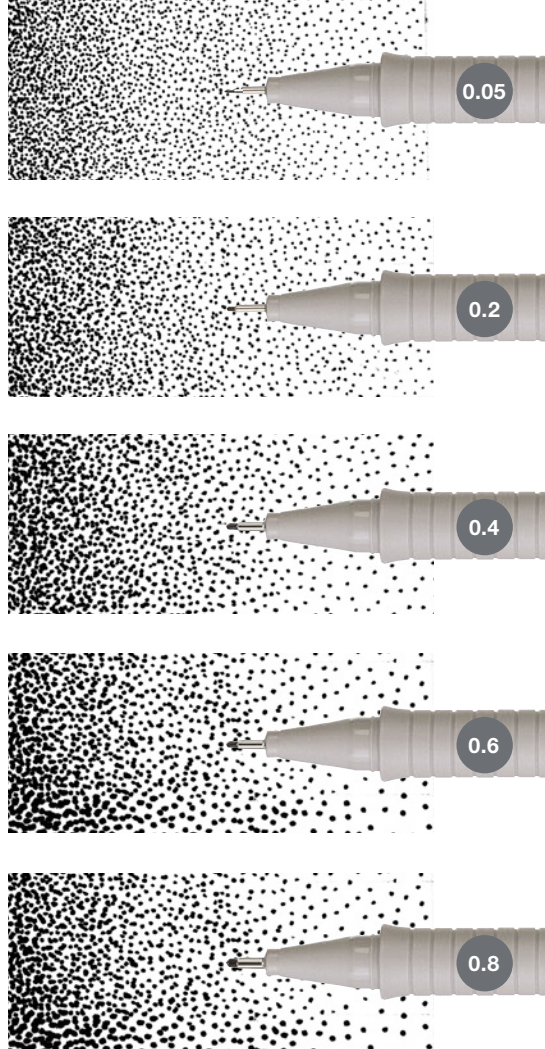

Technical drawing

The Ecco Pigment can be used for the final artwork in technical drawings. The preliminary sketch drawn with a pencil is traced over with the ink pen. When the pencil strokes are erased, the ink stroke remains in place clean and clear.

The Ecco Pigment is ideally suited for technical drawing. The long, metal-clad nib is perfect for drawing with rulers and templates. The different line widths enable clear, fine and standardised lines to be drawn.

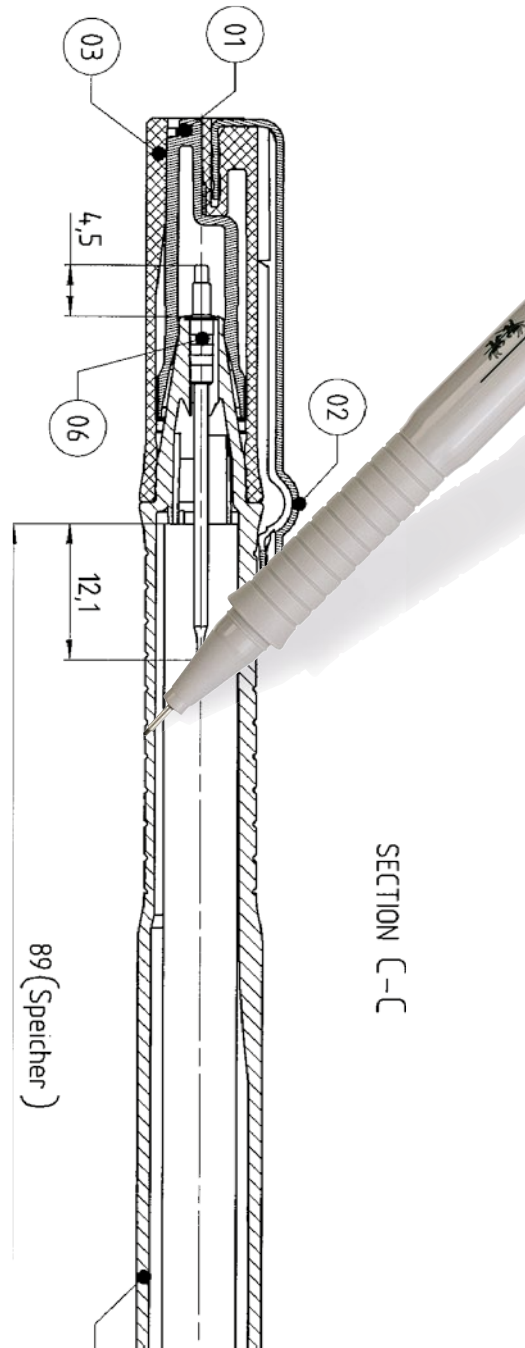
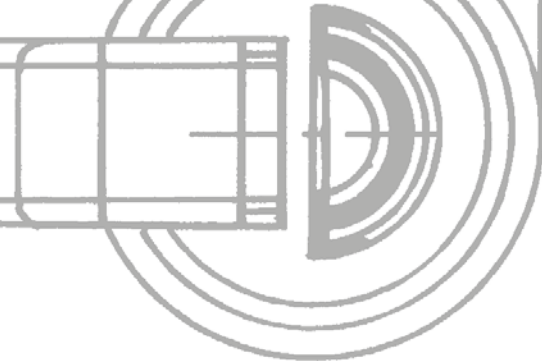

Illustration

Illustrating is a real pleasure with Ecco Pigment fineliners. The usage options are endless: as a line drawing, for highlighting in watercolour or acrylic pictures, for quick sketches while on the move, for combining in collage techniques.

Many illustrators prefer to draw a line drawing by hand and to continue working on it on the computer. The exact line of the Ecco Pigment impresses in this field too with loss-free digitisation.



Comic



Felix Görmann

*Born in Berlin, Germany
Artist name: Flix
Communication design studies
in Saarbrücken and Barcelona
Works as a comic illustrator for
newspapers and publishers on
a national and international level
www.flix.de*

“I love telling stories. For me, the comic is the most natural way to do this. Distinct, clear pictures are created with distinct, clear lines. And the best way to achieve this is with the Ecco Pigment fineliner. It doesn't smudge and stays black even if I erase the preliminary pencil sketch.”

SAVE THE
PLANET!
(IT'S THE ONLY
ONE WITH COFFEE.)

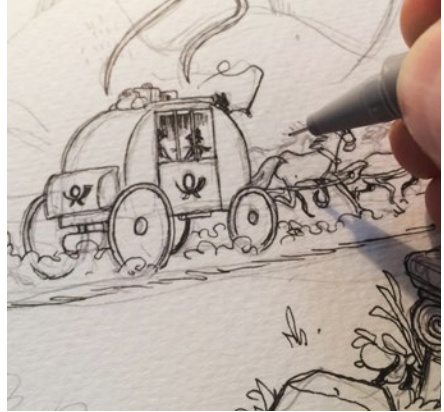

Pointillism



Giulio Stoppani

Born in Milan, Italy

Autodidact

Graphics, pointillism, engravings

www.zeropuntouno.eu

“No pencils, no brushes, no computer. A good technical pen, a black and white idea to re-create, a clean white sheet of rough paper, a hand tapping tirelessly in a syncopate dance for dozen of hours, at one tenth of millimeter from reality.”

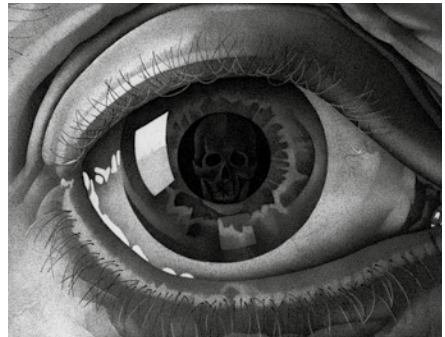
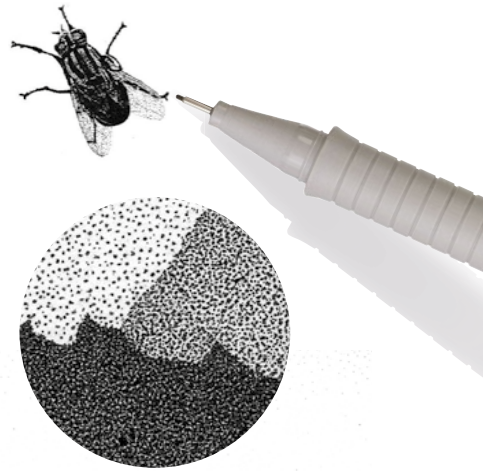

Mandala · Zentangle® · Tattoo



Natalie Gehre

*Born in Erlabrunn, Germany
Member of the Hof art association
Part-time artist
<http://atelier-1984.jimdo.com>*

"I find Ecco Pigment fineliners to be extremely reliable. They can be used for mandalas, Zentangle® pictures, tattoo designs and for highlighting portraits. The 0.05 nib is particularly great for drawing eyelashes, for example. The different thicknesses mean that mandalas and Zentangle® pictures can be drawn extremely precisely and accurately without overlapping multiple "layers". The ink is absorbed quickly by the paper and does not smudge. The pen sits optimally in the hand and has a truly versatile range of uses."



Calligraphy · Handlettering



Joachim Propfe

*Born in Mannheim, Germany
Colour design and calligraphy studies
in Hildesheim*

*Colour designer and font artist
<http://www.kalligrafie-propfe.de>*

"I really like working with fineliners like the Faber-Castell Ecco Pigment, as they are perfect for quick calligraphy sketches or handlettering. The pens with the thicker 0.5 to 0.7 nibs can be used like small dip pens, the thinner nibs are great for fine, elegant handwriting."

Pitt Artist Pen

I'm an
IDEALIST.

I don't know
where I'm going,
but I'm on
my way.

Better three hours too soon
than one minute too late.

WILLIAM SHAKESPEARE



But
a little chocolate
now and then
DOESN'T HURT

Pitt Artist Pen

Mixed media

Ecco Pigment + Castell 9000

The Ecco Pigment is the optimal choice for strong contours and for defining highlights. Shading with the Castell 9000 in different grades does not cover the Ecco Pigment, the lines remain clear and black.

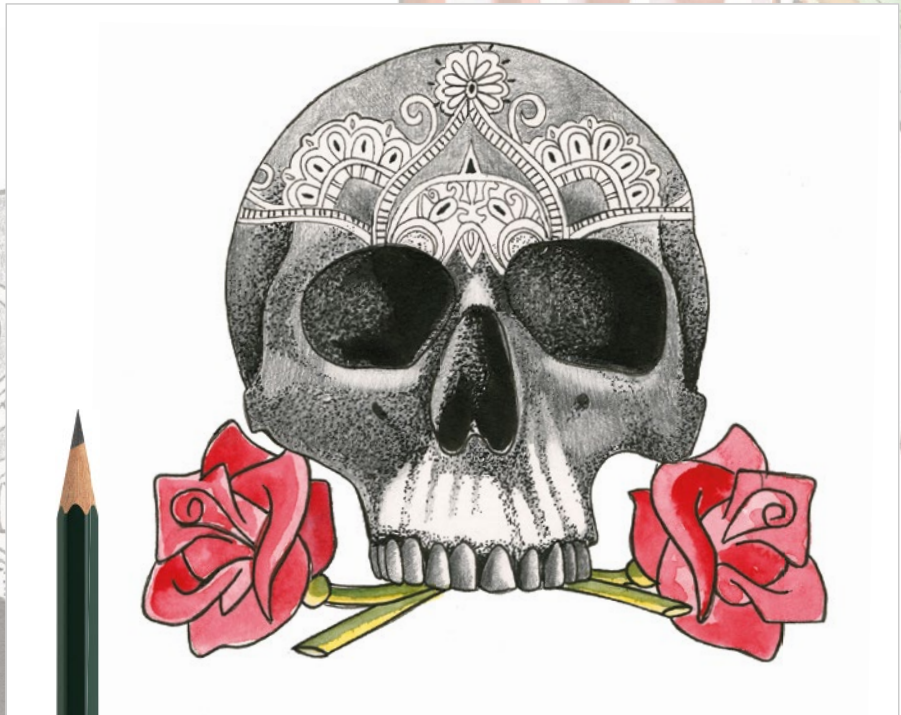



FABER-CASTELL
since 1761

Ecco Pigment + Albrecht Dürer artists' watercolour pencils



When used in combination with the Albrecht Dürer artists' watercolour pencils, the Ecco Pigment impresses with its waterproof qualities. Pre-sketched lines do not change and remain in place when watercolour is applied.



